

Model 550

4 port configuration - 22,22mm PCD
Medium/High Response
Mechanical Feedback
Electrohydraulic Servovalve

star
hydraulics
SERVO TECHNOLOGY & RESEARCH

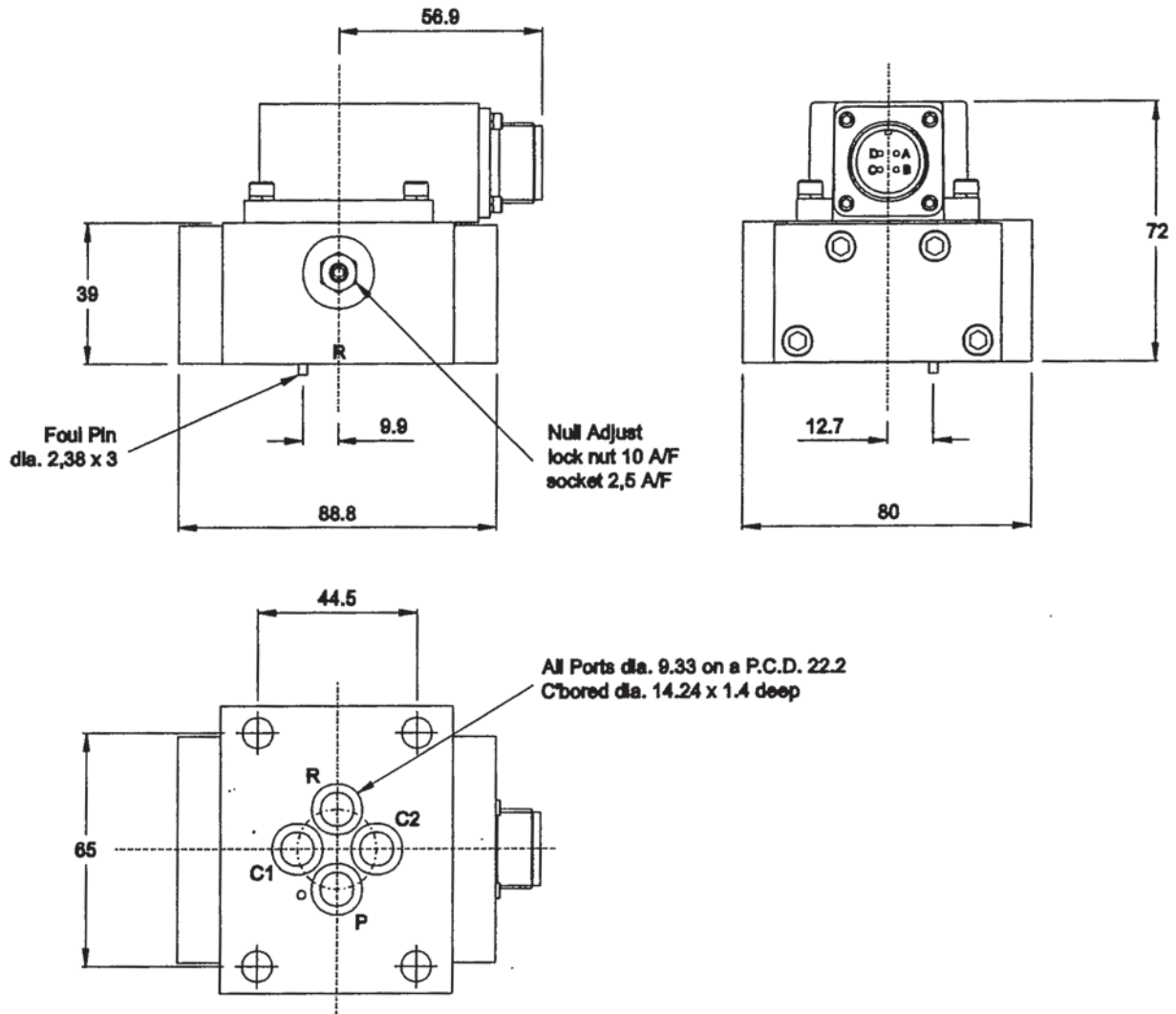

Installation Data

Suggested mounting screws: M8 x 50mm high tensile steel socket head cap screws, torque to 29 N.m [257 lbf.in].
Electrical connector is available at $\pm 90^\circ$ or 180° to position shown (over P port as standard).
Mating connector: 3106-14S-2S.
Base seals: BS013 [10,82 mm I/D x 1,78 mm section].
Mounting surface requires a finish of Ra 0,8 μm flat within 0,02 mm.
Null adjustment: flow from C2 will increase with clockwise rotation of the null pin, alternatives available.
Mass: 1,0 Kg.

Technical Specification

Threshold	< 0.5% without dither
Hysteresis	< 3.0% without dither
Null bias	< 2.0%
Null shift with 40°C temperature change	< 2.0%
80% to 110% pressure change	< 2.0%
Pressure gain	>30% supply pressure for 1% rated input signal, can be as high as 100%
Supply pressure minimum recommended	15 bar
maximum continuous	210 bar (standard) 315 bar (special order)
Proof pressure at pressure port	150% max supply pressure
at return port	100% max supply pressure
Burst pressure return port open	250% max supply pressure
External leakage	zero
Operating temperature range	-20°C to +130°C
Fluid	Petroleum based mineral oil 10 to 110 cSt at 38°C
Seal material	Fluorocarbon other materials on request
Supply filtration recommended	15µm absolute or better ($\beta_{15} > 75$)

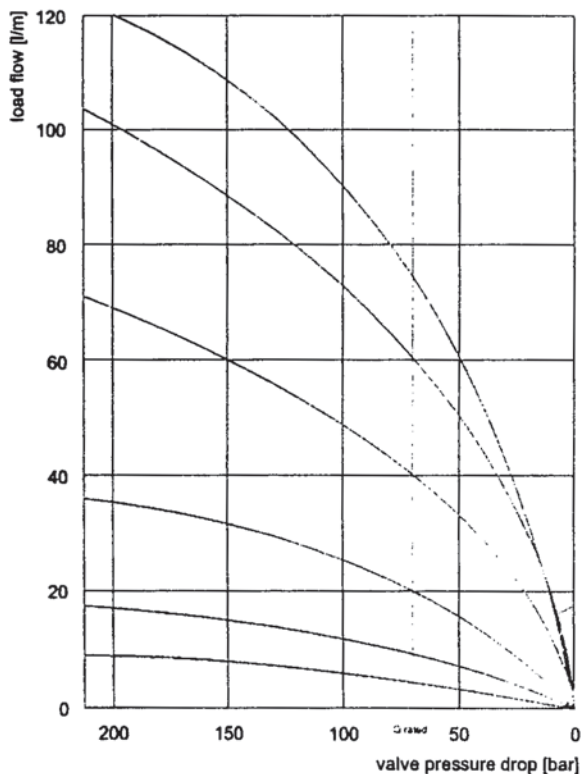

Figure 1

The nominal rated flow of a servovalve is the load flow under conditions of 100% electrical input and 70 bar total valve pressure drop. The load flow pressure characteristic closely approximates the theoretical square-root relationship of a sharp edged orifice (figure 1).

The flow tolerance for standard servovalves is $\pm 10\%$ of the nominal rated flow at $\pm 100\%$ input signal. Flow gain at null is determined by the relationship of the spool and bushing metering edges and may vary with standard production tolerances, flow gain in the region of $\pm 5\%$ rated current from null may range from 50% to 200% of the nominal flow gain (figure 2).

The null leakage comprises of both pilot stage flow (tare leakage) and the second stage null leakage (table 1).

Figure 2

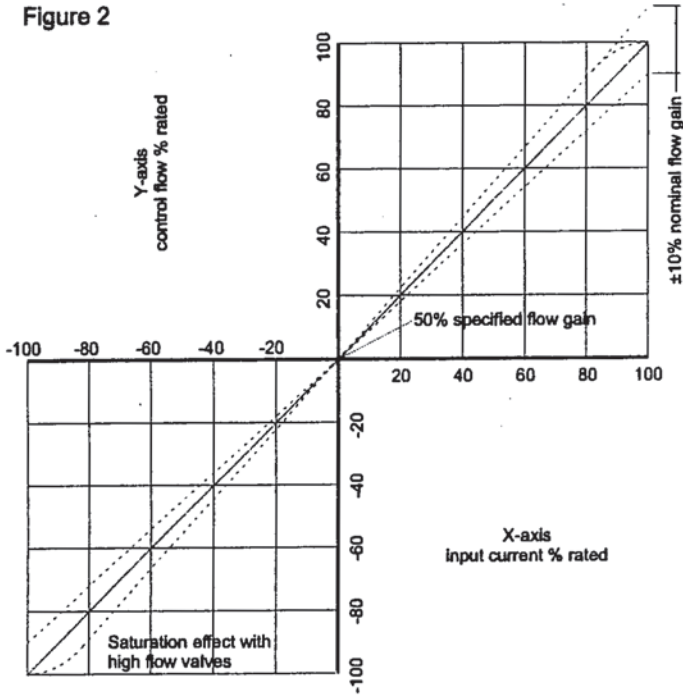

Table 1

Nominal flow ratings at 70 bar Δp [l/min]	Null leakage 140 bar supply [l/min]
4	< 1,0
10	< 1,2
20	< 1,6
40	< 1,6
60	< 1,6
75	< 1,6

Electrical Characteristics

Coil specification		Series		Parallel	
Differential rated current [mA]	Resistance per coil [Ω]	Rated current [±mA]	Effective resistance [Ω]	Rated current [±mA]	Effective resistance [Ω]
10	1000	5	2000	10	500
15	200	7,5	400	15	100
20	1200	10	2400	20	600
30	300	15	600	30	150
30	800	15	1600	30	400
40	80	20	160	40	40
60	40	30	80	60	20
80	22	40	44	80	11
100	27	50	54	100	13,5
200	22	100	44	200	11
400	22	200	44	400	11

Coil ratings are specified in terms of the differential rated current [mA] and the resistance per coil [Ω]

External connections for standard polarity (flow out of C2) are:-
 Parallel coil configuration: link A to C & B to D : A & C +ve, B & D -ve
 Series coil configuration: B & C linked : A +ve, D -ve
 Single coil configuration: A +ve, B -ve or C +ve, D -ve

Figure 3

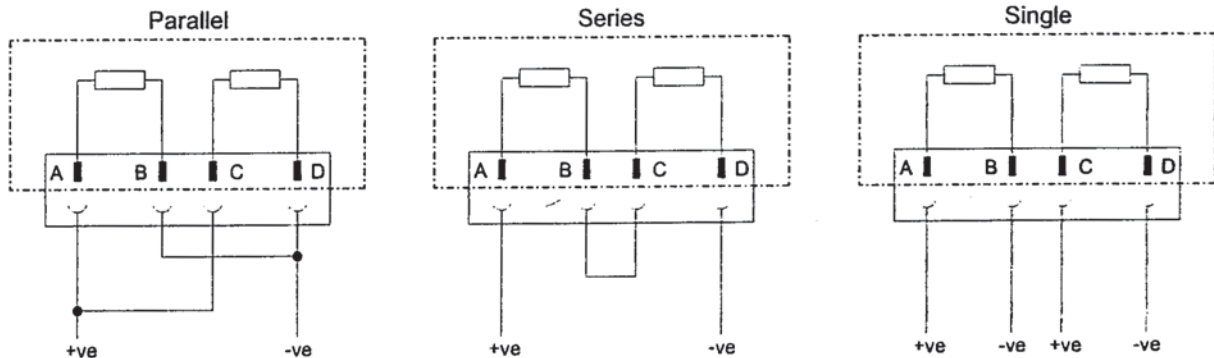

Transient Response

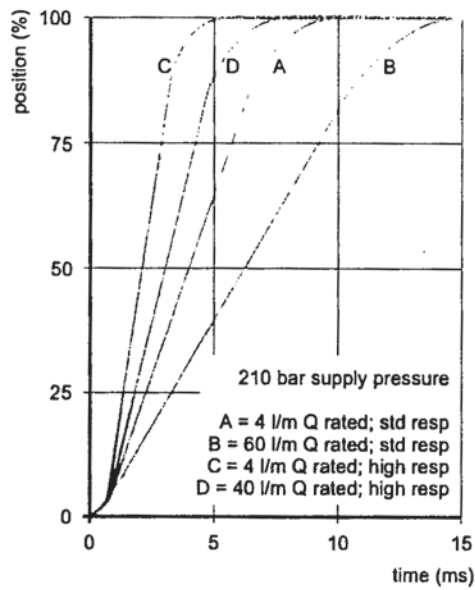

Dynamic Response

